

Ca-Zoom[®] 6.2

Remote Visual Inspection





Contents

- 1 Overview
- 2 System Features
- 6 Software Features
- 8 Application / Industries
- 11 Modular System and Accessories
- 12 PC Connectivity / Applications
- 13 Specifications

Ca-Zoom® 6.2



Inspecting chemical plant vessel with PTZ140 system, extension pole and swivel ball tripod.

The Ca-Zoom 6.2 puts image management in the palm of your hand with interchangeable camera heads, advanced camera setup, integrated image capture and full motion video recording capabilities, on-board file manager, annotation and comparison measurement features.

- Three interchangeable camera head diameter options
- High-performance, variable dual-lighting control
- High-resolution images (470 HTV Lines)
- Integrated temperature warning system
- Camera Control Unit with 64MB internal flash memory and CompactFlash® removeable Storage Media
- Still image or motion video capture
- USB® streaming digital video output
- On-screen zoom magnification, pressure, PTZ position, time/date character generation display and user logo
- Unitized (no exposed wiring), all-in-one camera head construction
- Remote operation with hand-held controller with built-in color VGA LCD monitor to control zoom, lighting, image control and measurement
- In-air or underwater operation
- Portable operating / carrying case with industrial wheels

Hardware Features

CA-ZOOM® 6.2 Digital Inspection System™ shown here with standard equipment. System can be equipped with the interchangeable PTZ70, PTZ100 and/or PTZ140 camera heads.



PTZ70 camera head with shipping/storage case



PTZ140

Incorporates a 36x optical with a 12x digital for a 432x total zoom capability. Additionally, the camera is equipped with two high-power 35 watt lights offered with wide and narrow beam spreads.



PTZ100

Incorporates a 10x optical with a 4x digital for a 40x total zoom capability. Additionally, the camera is equipped with four 5-watt LED lights offered with wide and narrow beam spreads.



PTZ70

Incorporates a 10x optical with a 4x digital for a 40x total zoom capability. Additionally, the camera is equipped with eight 5-watt LED lights offered with wide and narrow beam spreads.

Camera head/optics The Ca-zoom® 6.2 camera heads are enclosed, inertly pressurized and sealed to protect sensitive electronics when submerged.



Hand-held controller

The hand-held controller may be used at distances up to 15 m (50 ft) from the camera control unit. The unit contains a 6.4 in. diagonal color VGA resolution LCD monitor, dual joysticks for camera pan and tilt: control buttons for zoom, lighting, image control, and extensive menu functions for image management.



Cable/Cable Reel

Rugged cable and cable reel for operation up to 500 m (1640 ft). Underwater operation up to 45 m (150 ft.).



Camera Control Unit (CCU) / Processor

Portable, case-mounted, or rack-mounted camera controller. A Pentium®-class processor runs a real-time, multitasking software operating system which supports file storage on 64MB of internal flash memory and CompactFlash, removeable storage media. Includes connectors for camera, two hand-held controllers, video input/output, USB streaming video output and keyboard for text generation.



Accessory Keyboard

CCU contains an integrated text generator which may be operated using the hand-held controller's joystick, or an external keyboard.



Portable Shipping/ Operating Case

Ca-Zoom 6.2 cuts down on setup and teardown time by incorporating system components into a portable, wheeled shipping case. Just roll it to the inspection site and operate the system right from the case.

System Hardware

With the Ca-Zoom® 6.2 Digital Inspection System™, GE Inspection Technologies now offers three camera head options to enable you to increase your inspection capabilities from one base platform. Built-in control functions and advanced iVIEW™ image management platform are all packaged into one unit.

PTZ140

A: Camera Module

36x Optical (12x digital) Zoom Camera Module

B: Dual-Controlled High-Powered Lighting

2 lamps, 35 W each, with focused dichroic reflectors, spot or flood illumination available, Turbo lamp mode: 40 W total

C: Tilt Capability

234° total tilt (+129°/-105°)

D: Slip-Clutch Mechanism

Prevents internal damage to pan and tilt components

E: Pressurized Purge Valve

Check pressure integrity

F: Pan Capability

360° total (+/-180°)
Optional 360° continuous pan capability

G: Unitized Connectors

Heavy-duty underwater connector with steel keyway for safe alignment

H: Lightweight

Anodized aluminum or optional stainless steel housing



PTZ 140 with optional laser accessory

	PTZ140	PTZ100	PTZ70
Weight	3.0 kg (6.7 lb) – Aluminum	1.8 kg (3.9 lb) – Aluminum	2.5 kg (5.5 lb) – Aluminum
Size	287.0 mm (12.60 in) L x 139.7 mm (5.49 in) ø Fits through a 140 mm (5.5 in) ø opening	194.0 mm (7.65 in) L x 98.4 mm (3.88 in) ø Fits through a 100 mm (3.94 in) ø opening	468.0 mm (18.4 in) L x 69.8 mm (2.75 in) ø, Fits through a 76 mm (3.00 in) ø opening

PTZ100

A: Camera Module

10x Optical (4x digital) Zoom Camera Module

B: High-Performance Lighting

Spot or flood illumination available.
Turbo lamp mode: 11 W total

C: Tilt Capability

Mechanical: 340° total (+/-170°)
Optical wide-angle: 256° total (+/-128°)
Optical tele-zoom: 280° total (+/-140°)

D: Slip-Clutch Mechanism

Prevents internal damage to pan and tilt components

E: Pan Capability

354° total (+ / - 177°)

F: Unitized Connectors

Heavy-duty underwater connector with steel keyway for safe alignment

G: Pressurized Purge Valve

Check pressure integrity

H: Lightweight

Anodized aluminum housing



PTZ 100 with optional laser accessory

PTZ70

A: Camera Module

10x Optical (4x digital) Zoom Camera Module

B: High-Performance Lighting

Spot or flood illumination available. Turbo lamp mode: 20 W per channel

C: Tilt Capability

270° total (+/- 135°)

D: Slip-Clutch Mechanism

Prevents internal damage to pan and tilt components

E: Pan Capability

360° Continuous

F: Pressurized Purge Valve

Check pressure integrity

G: Lightweight

Anodized aluminum housing

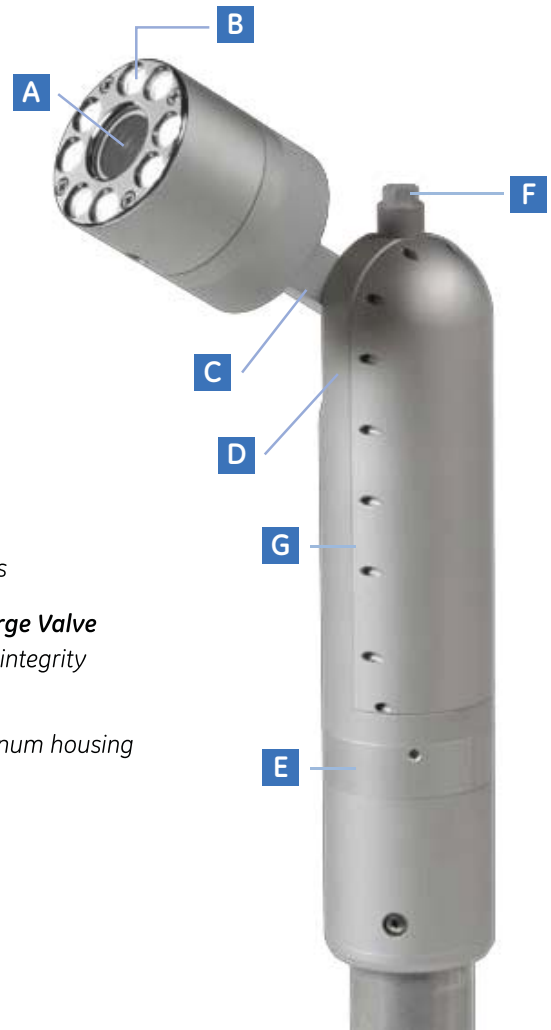

Software Features

The Ca-Zoom® 6.2 puts image control in the palm of your hand – letting you capture, file, compare, annotate, measure and review at the touch of a button. Position the camera, adjust the lights, zoom in on the problem and record the evidence.

The left side of the hand-held controller lets the operator control the camera functions, including zoom, focus, lights and image brightness. The right side provides image management and on-screen menu options.



A: Soft Buttons

Context sensitive buttons using on-screen labels

B: Zoom

Activate optical zoom and control digital zoom with soft buttons

C: Focus

Control camera focus in manual mode. (autofocus enable/disable)

D: Lights

Select flood and/or spotlights and control brightness with soft buttons

E: Image Brightness

Controls camera gain, iris and electronic shutter

F: Volume

Raise/lower playback volume

G: Screen

Large 16 cm (6.4 in) diagonal VGA-resolution color screen gives the operator a clearer, sharper view of live images, or images recalled from memory.

H: Save

Saves images at the touch of a button

I: Freeze

Instantly freezes the on-screen image for better assessment

J: Menu

Enable on-screen menus

K: Enter

Selects highlighted on-screen menu selections

L: Exit

Exits on-screen menu selections



Advanced Camera Setup



Advanced Image Control



Position Settings



Temperature Sensor

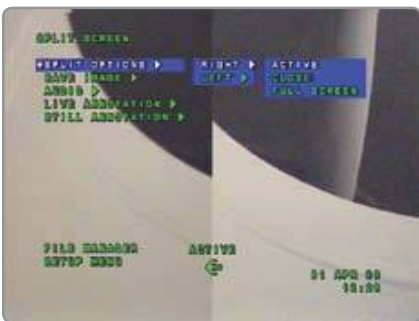

Split-Screen Menu



Laser Measurement



On-Screen Display of Temperature, Pressure, PTZ position, Time & Date and your logo



File Manager

iVIEW™ Image Management Platform Features Include:

Multi-Function Joystick

Dual joystick controls for camera pan-and-tilt, menu navigation and character generator control.

Intuitive Drop-Down Menu System

Access the advanced feature set via a drop-down menu system.

Advanced Camera Setup

Menu-driven setup features provide options for enabling or disabling the digital zoom range, brightness (shutter, iris, gain), inverted control of pan-and-tilt, and camera home positioning.

Laser Measurement

Parallel laser accessory mounted on the camera head provides a reference for measurement on a perpendicular surface.

Position Settings

Set camera home and zero positions by moving the camera to the desired location and saving this setting. Set up to 10 additional preset locations, for saving pan-tilt-zoom settings.

Image Freeze and Storage

A single-button press activates image storage. A separate button provides a freeze-only function.

File Manager

A full-featured embedded file management system with a thumbnail-based image and video recall system. Create and name file folders, and move and store files between folders on internal flash memory and CompactFlash® removable media storage.

Integrated Text Generator with Arrow Annotation

Text annotation and graphic callout arrows can be placed onto the live display or any frozen or recalled image. Text can be created using an external keyboard or the pendant's joystick. Create preset text messages in advance and quickly recall them during inspection operations. Your company logo, or other bitmap file, can be stored with captured images and displayed on-screen.

Digital Video Recording

Capture and record MPEG2 or MPEG1 video, either on its internal 64 MB flash memory or on the removable CompactFlash® (CF) cards. The system also provides a USB port which provides full VGA streaming digital video output.

Multi-Language Interface

Select from English, German, Italian, and Russian for on-screen text annotation. Custom language capability also available.

Applications / Industries

The Ca-Zoom® 6.2 Digital Inspection System™ helps process and power industries throughout the world maintain efficient operation and lower costs by reducing or eliminating downtime and lost production time, as well as improving worker safety.

Power and Process Applications:

- Tank and Vessel Inspection
- Weld Inspections
- Corrosion Evaluation
- Coke Drum Lining Inspection
- Tray Towers
- Floating Roof Inspection
- Fractionation Towers
- Refractory Lining
- Railroad and Truck Tank Cars
- Cleaning Validation
- HVAC, Elevator and Mine Shaft



PTZ assists with confined space inspection



Spray ball coverage inspection for cleaning validation



Detached agitator blade in mixing vessel due to broken bolts



Tank and vessel inspection

Ca-Zoom systems provide the remote viewing capabilities allowing inspection of vessels for cleanliness, defects, interior indications of cracks and many other features of the vessel surface. The collection of digital images of the inspection allows for historical comparisons of previous vessel inspections to identify and track changes of tanks or vessel profiles.



Riboflavin rinse inspection for cleaning validation



Pharmaceutical tank inspection through 76 mm (3.0 in) \emptyset nozzle



Inspection through a 100mm (3.94 in) \emptyset nozzle



Glass-lined vessel inspection through Pharmaceutical tank inspection through 76 mm (3.0 in) \emptyset nozzle

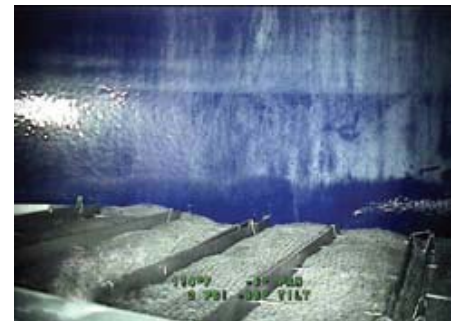

Glass-lined vessel filter tray inspection

Nuclear Applications:

- Tanks and Vessels
- ALARA
- Reactor Vessel
- On-line Monitoring
- Nuclear Fuel Bundle/Serial Number Verification
- Fuel Movement and Refueling Operations
- Fuel Bundle Failure Analysis
- Spent Fuel Pool
- Reactor Coolant Pump
- BWR Core Shroud Examination
- Jet Pumps
- CRDM and BMI Inspections
- Large Pipe Inspection
- Remote Monitoring of Contaminated Rooms and Hot Cells
- Steam Generator Bowl and Secondary Side Inspection
- Remote Tooling
- FOSAR



Serial number inspection of nuclear fuel.



BWR core shroud weld examination



Operators perform nuclear reactor vessel visual inspections with Ca-Zoom PTZ Digital Inspection System

The advanced Ca-Zoom® 6.2 Digital Inspection System™ facilitates efficient inspection and surveillance activities in the power generation industry.

The Ca-Zoom 6.2 series of PTZ cameras are used extensively in nuclear power plants and nuclear waste management facilities and is the equipment of choice for major service companies worldwide. The Ca-Zoom 6.2 system facilitates efficient inspection and surveillance activities and its versatile design provides outage service personnel with equipment for a wide range of applications.

In the nuclear industry, the systems are used for inspection or surveillance activities in refueling, reactor vessel maintenance and for in-service inspections. Loose parts, tools or debris dropped into power generation systems may be retrieved from hard-to-reach areas without the need for disassembly of plant equipment with the aid of the Ca-Zoom 6.2.

Modular System and Accessories

Base System



PC Connectivity / Applications



iVIEW™ Remote PTZ

Allows full capability of remote inspections, from either the next room or across the world, via high-speed Internet connection. Once the Ca-Zoom® 6.2 is connected to a PC at the inspection site, a remote user has full access to all menu functions, can control camera movement and utilize all advanced camera capabilities. iVIEW Remote supports MPEG4-based motion video capture and allows still capture to laptop or PC.

iVIEW PC

FREE software which allows you to manipulate, re-measure and compare, annotate, e-mail images to other locations, review inspection results, and generate automatic reports in Microsoft® Word™ format. Download iVIEW PC from the GE Inspection Technologies website or obtain a copy on CD-Rom from GE Inspection Technologies Remote Visual Inspection Customer Service.



Specifications: PTZ140

Camera

Type: Color 1/6 in. EXview HAD CCD® (NTSC and PAL)
Resolution: 470 HTV Lines NTSC, 460 HTV Lines PAL
Zoom: 36x optical, 12x digital for a total 432x, f=2.4 mm to 60 mm
Field of View: In-air: 1.7° H x 1.3° V in telephoto; minimum distance of 1500 mm (59.1 in)
 In-air: 57.8° H x 43.4° V in wide-angle; minimum distance of 320 mm (12.6 in)
Focus: Automatic & manual
Iris: Automatic & manual (f1.6 – close)
Electronic Shutter: Automatic & manual (1/10,000 sec – 1 sec)
Sensitivity: 1.4 lux at 1/60th sec; gain adjust -3 dB – 28 dB
Construction: Anodized aluminum or stainless steel

FIELD OF VIEW

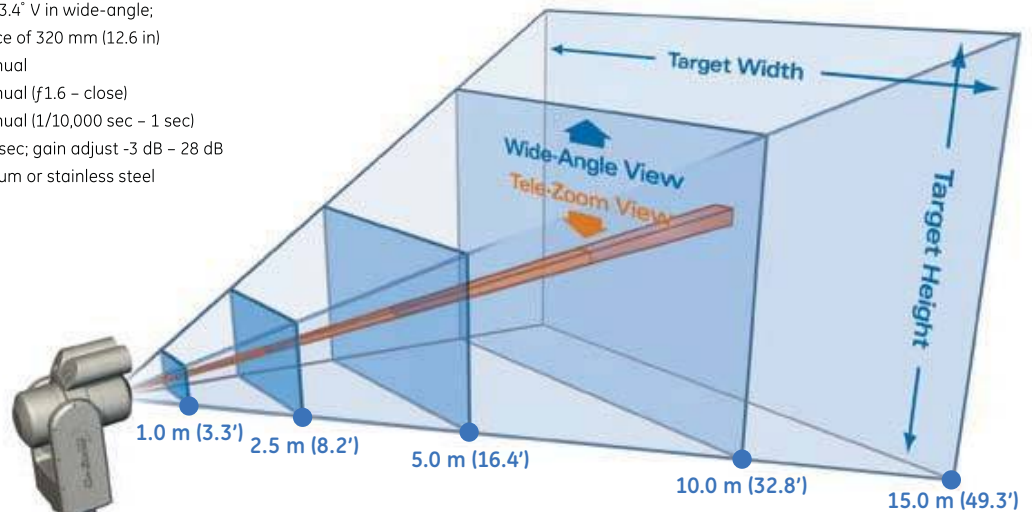

		1.0 m (3.3')	2.5 m (8.2')	5.0 m (16.4')	10.0 m (32.8')	15.0 m (49.3')
Wide-Angle View (58° H x 43° V)	Target Width	1.1 m (3.6')	2.76 m (9.1')	5.52 m (18.1')	11.04 m (36.2')	16.56 m (54.3')
	Target Height	795 mm (2.6')	1.99 m (6.5')	3.97 m (13.0')	7.95 m (26.1')	11.92 m (39.1')
	Screen Magnification†	0.12 x	0.05 x	0.02x	0.01 x	0.008 x
Tele-Zoom View (1.7° H x 1.3° V)	Target Width	30 mm (1.18")	74 mm (2.91")	148 mm (5.83")	297 mm (11.69")	445 mm (1.46')
	Target Height	22 mm (0.87")	56 mm (2.2")	111 mm (4.37")	223 mm (8.78")	334 mm (1.1')
	Screen Magnification†	4.38 x	1.75 x	0.88 x	0.44 x	0.29 x

All values are measured "in air" and are approximate with slight variations based on NTSC or PAL format. Multiply values by 0.75 for underwater FOV or target size. Magnification increases x1.33 for underwater use.

†Screen magnification calculated assuming 6.4" diagonal LCD screen.

Lighting

Two lamps – 35 W each with focused dichroic reflectors

35 W flood: 650 lumens (1300 cp) @ 30° (half-angle) beam spread

35 W spot: 650 lumens (4800 cp) @ 10° (half-angle) beam spread

Turbo lamp mode: 80 W total

Pan & Tilt

	Pan	Tilt
Range:	360° (+/-180°)	234° total (+129°/-105°)
Speed:	0 – 9°/sec.	0 – 9°/sec.
Torque:	0.9 Nm max 8 inch lb max	0.9 Nm max 8 inch lb max
Clutch-protected:	Yes	Yes

Weight: 3.0 kg (6.7 lb) aluminum*
Size: 287.0 mm (12.6 in) L x 139.7 mm (5.47 in) ø
 Fits through a 140 mm (5.5 in) ø opening
Mounting: Four 1/4 – 20 mounting points
Feedback: 10k ohm potentiometer position feedback

*Available in stainless steel @ 6.0 kg (13.2 lb)

PAN AND TILT

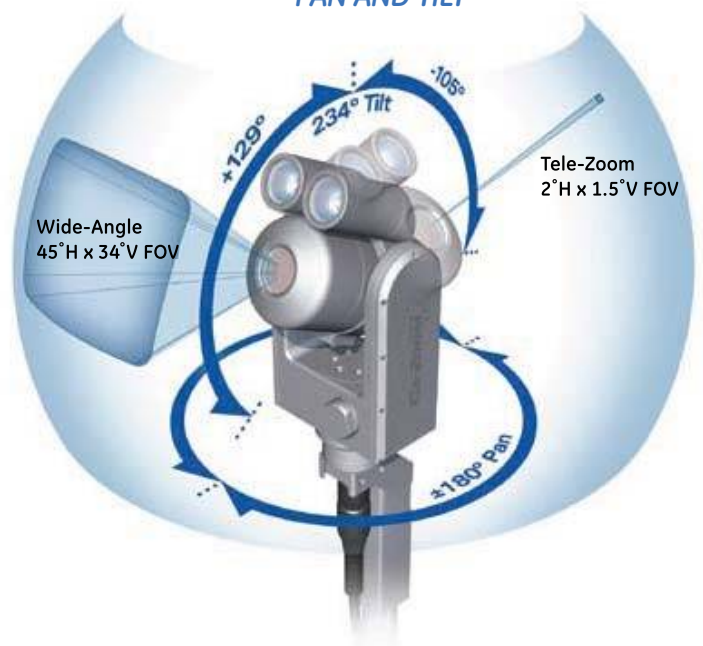

Specifications: PTZ100

Camera

Type: Color 1/4 in. EXview HAD CCD® (NTSC and PAL)
Resolution: 470 HTV Lines NTSC, 460 HTV Lines PAL
Zoom: 10x optical (4x digital) for a total of 40x (f=4.2 mm to 42 mm)
Field of View: In-air FOV is 4.6° H x 3.5° V in telephoto; minimum distance of 1000 mm (39.4 in)
 In-air FOV is 46° H x 35° V in wide-angle; minimum distance of 10 mm (0.4 in)
Focus: Automatic & manual
Iris: Automatic & manual (f1.8 - close)
Electronic Shutter: Automatic & manual (1/10,000 sec - 1 sec)
Sensitivity: 1.5 lux at 1/60th sec; gain adjust -3 dB - 28 dB
Construction: Anodized aluminum

FIELD OF VIEW

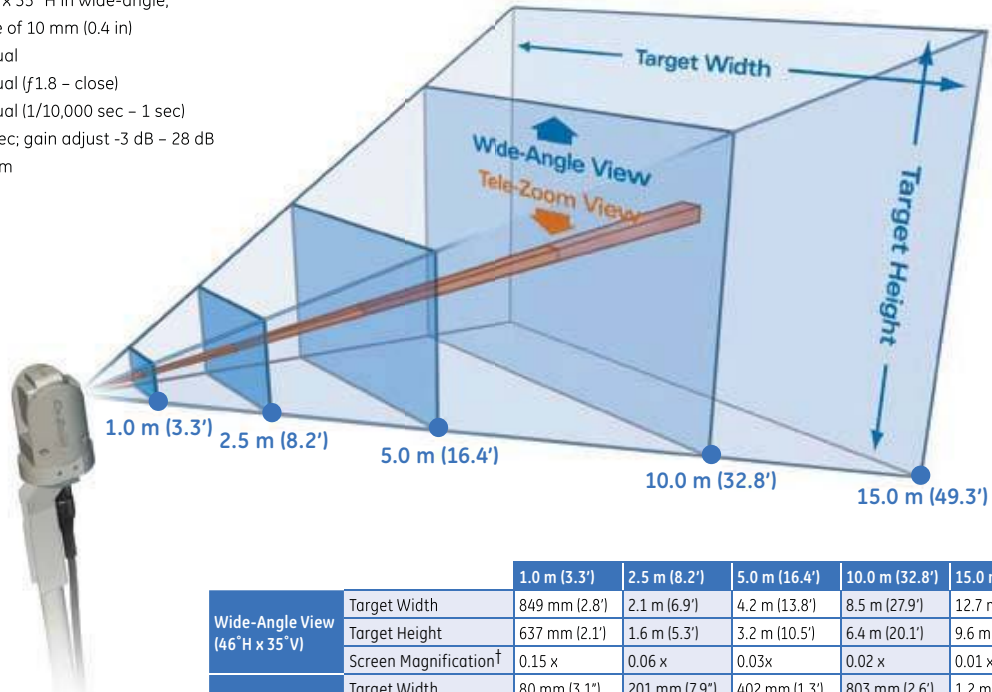

		1.0 m (3.3')	2.5 m (8.2')	5.0 m (16.4')	10.0 m (32.8')	15.0 m (49.3')
Wide-Angle View (46° H x 35° V)	Target Width	849 mm (2.8')	2.1 m (6.9')	4.2 m (13.8')	8.5 m (27.9')	12.7 m (41.7')
	Target Height	637 mm (2.1')	1.6 m (5.3')	3.2 m (10.5')	6.4 m (20.1')	9.6 m (31.5')
	Screen Magnification†	0.15 x	0.06 x	0.03x	0.02 x	0.01 x
Tele-Zoom View (4.6° H x 3.5° V)	Target Width	80 mm (3.1')	201 mm (7.9')	402 mm (1.3')	803 mm (2.6')	1.2 m (3.9')
	Target Height	61 mm (2.4')	153 mm (6.0')	306 mm (1.0')	611 mm (2.0')	917 mm (3.0')
	Screen Magnification†	1.63 x	0.65 x	0.32 x	0.16 x	0.11 x

All values are measured "in air" and are approximate with slight variations based on NTSC or PAL format. Multiply values by 0.75 for underwater FOV or target size. Magnification increases x1.33 for underwater use.

†Screen magnification calculated assuming 6.4" diagonal LCD screen.

Lighting

Four lamps - 2 x 2 control

10 W flood: (2 x 5 W) white LED 240 lumens (200 beam cp) @ 30° beam spread
10 W spot: (2 x 5 W) white LED 240 lumens (900 beam cp) @ 10° beam spread
Turbo lamp mode: 22 W total

Pan & Tilt

	Pan	Tilt
Range:	354° total (+/-177°)	Mechanical: 340° total (+/-170°) Optical wide-angle: 256° total (+/-128°) Optical tele-zoom: 280° total (+/-140°)
Speed:	0 - 9°/sec.	0 - 9°/sec.
Torque:	0.9 Nm max 8 inch lb max	0.9 Nm max 8 inch lb max
Clutch-protected:	Yes	Yes
Weight:	1.8 kg (3.9 lb)	
Size:	194 mm (7.65 in) L x 98.4 mm (3.88 in) ø Fits through a 100.0 mm (3.94 in.) ø opening	
Mounting:	Four 1/4 - 20 mounting points	
Feedback:	10k ohm potentiometer position feedback	

PAN AND TILT



Specifications: PTZ70

Camera

Type: Color 1/4 in. EXview HAD CCD® (NTSC and PAL)
Resolution: 470 HTV Lines NTSC, 460 HTV Lines PAL
Zoom: 10x optical (4x digital) for a total of 40x (f=4.2 mm to 42 mm)
Field of View: In-air FOV is 4.6° H x 3.5° V in telephoto; minimum distance of 1000 mm (39.4 in)
 In-air FOV is 46° H x 35° V in wide-angle; minimum distance of 10 mm (0.39 in)
Focus: Automatic & manual
Iris: Automatic & manual (f1.8 - close)
Electronic Shutter: Automatic & manual (1/10,000 sec - 1 sec)
Sensitivity: 1.5 lux at 1/60th sec; gain adjust -3 dB - 28 dB
Construction: Anodized aluminum

FIELD OF VIEW

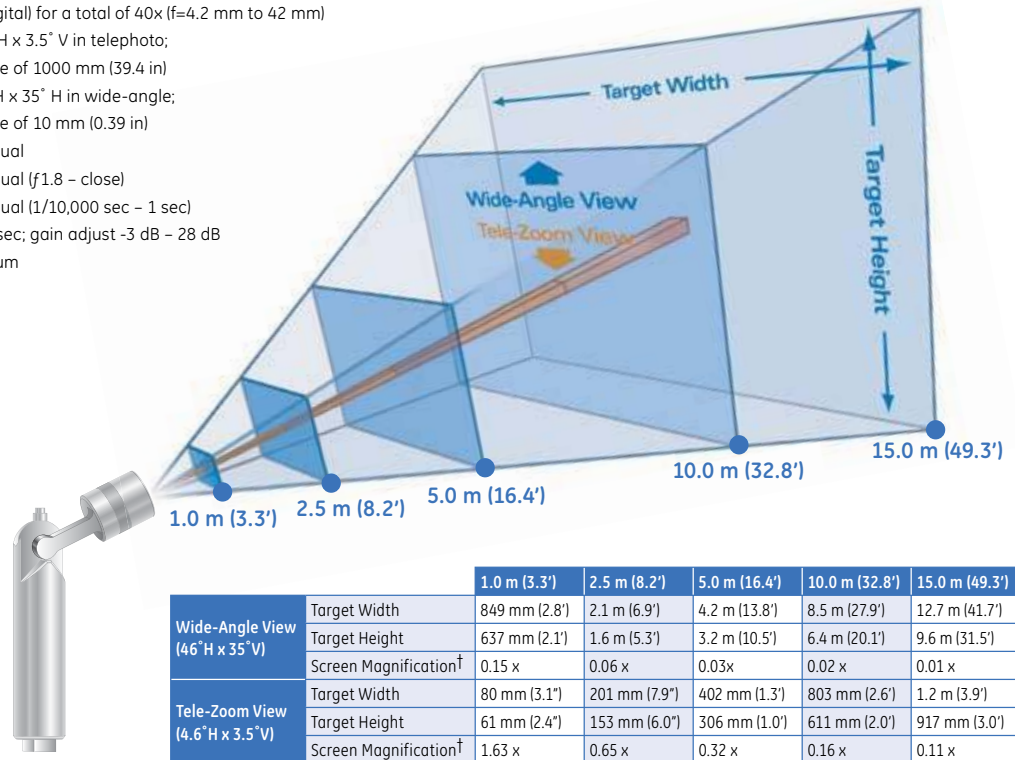

All values are measured "in air" and are approximate with slight variations based on NTSC or PAL format. Multiply values by 0.75 for underwater FOV or target size. Magnification increases x1.33 for underwater use.

†Screen magnification calculated assuming 6.4" diagonal LCD screen.

Lighting

Eight lamps - 4 x 4 control

20 W flood: (4 x 4 W) white LED 480 lumens (400 beam cp) @ 30° beam spread
20 W spot: (4 x 4 W) white LED 480 lumens (1800 beam cp) @ 10° beam spread
Turbo lamp mode: 20 W per channel

Pan & Tilt

	Pan	Tilt
Range:	360° continuous	270° total (+/- 135°)
Speed:	0 - 10°/sec	0 - 12°/sec
Torque:	1.8 Nm max 16.0 inch lb max	1.8 Nm max 16.0 inch lb
Clutch-protected:	Yes	Yes
Weight:	2.5 kg (5.5 lb)	
Size:	468 mm (18.4 in) L x 69.8 mm (2.75 in) ø, Fits through a 76 -mm or (3.00 in.) ø opening	
Mounting:	Four 1/4 - 20 mounting points	
Feedback:	Magnetic angular sensor	

PAN AND TILT



Technical Specifications

Camera Operating Environment

Temperature:	-18°-50°C (0°-122°F), short-term up to 70°C (158°F)
Pressure:	Waterproof to 45 m (150.0 ft.) or 4.5 bar (65 psi.) external
Radiation Tolerance:	
PTZ140:	Dose Rate: Approximately 10 Gy/hr (~1,000 R/hr) *50 Gy/hr (~5,000 R/hr) - Manual focus only Cumulative Dose: Approximately 600 Gy (~60,000 rads)
PTZ100:	Dose Rate: Approximately 10 Gy/hr (~1,000 R/hr) Cumulative Dose: Approximately 220 Gy (~22,000 rads)
PTZ 70:	Dose Rate: Approximately 10 Gy/hr (~1,000 R/hr) Cumulative Dose: Approximately 220 Gy (~22,000 rads)
Pressurization:	Schrader valve with protective cap 0.7 bar (10 psi.) internal for inert gas

Camera Control Unit (CCU)/Processor

Dimensions:	39.0 cm (15.4 in) L x 28.0 cm (11.0 in) W x 13.5 cm (5.3 in) D
Weight:	5.9 kg (12.9 lb)
Power Requirement:	AC Power Nominal input: 100-240V, 50-60Hz, 3 A
Processor:	32 bit Pentium®-class embedded computer system
Memory:	64MB internal Flash memory
Disk Drive:	CompactFlash®, Type 1, accepts all memory sizes
File Storage Capacity:	
Still Image Storage:	BMP uncompressed: 900KB typical file size JPG Super High Quality: 200KB typical file size JPG High Quality: 90KB typical file size JPG Low Quality: 30KB typical file size
Video Recording:	MPEG2: High and Low Quality Settings Up to 42 minutes recording on High w/1GB CF card MPEG1: High, Medium and Low Quality Settings Up to 92 minutes recording on Med w/1GB CF card
Video Output:	Composite, S-Video and USB 2.0 full VGA streaming digital video
Remote Control:	All functions may be controlled by a PC running iView Remote/PTZ Interface is serial RS-232 on DB-9F connector

Hand-held Controller

Monitor:	16 cm (6.4 in) diagonal full-resolution color VGA (640 by 480 pixels)
Temperature:	0° to 49°C (32° to 120°F)
Weight:	1.4 kg (3.1 lb)
Cable:	Ruggedized 5 m (16.0 ft)
Audio:	Built-in microphone, speaker and headset connector
Controls:	Back-lit buttons and joystick pan/tilt/menu navigation
Soft Buttons:	Programmable for enhanced camera operations

Optional Accessories

- Parallel Laser Measurement Accessory
- iVIEW™ Remote PTZ Software for controlling the Ca-Zoom® camera from a PC
- Second Video Hand-held Controller and 15 m (50.0 ft) controller cables
- Keyboard
- Telescoping and Interconnecting Poles; Swivel Ball or Standard Tripod
- Extension Cables
- Main Cables up to 500 m (1640.0 ft)
- Slip-Ring Cable Reels

iVIEW™ Software Features

Zoom:	PTZ140: 36x optical, 12x digital zoom control PTZ100/PTZ70: 10x optical, 4x digital zoom control Enable/disable digital zoom capability
Camera Setup:	User interface of camera setup: long exposure, invert image camera control, pan/tilt range, digital zoom on/off, image stabilization and IR filter on/off for PTZ140 only
Positions:	Set camera home and zero positions Choose up to 10 preset positions for pan-tilt and zoom
On-Screen Info.:	Zoom Magnification, Pressure (BAR/PSIG), Pan/Tilt position, Time/Date and Logo
Lighting Control:	Software-controlled variable lamp intensity, includes turbo boost mode
Split-screen:	The split-screen menu allows for viewing a combination of live and stored images on screen
Audio Annotation:	The audio annotation allows for up to 15 seconds of audio information to be recorded and associated with a stored image file
Text Annotation:	Built-in, full-screen text overlay generator using Joystick or PS/2 keyboard supports storage of up to 40, 2-line x 30 characters per line "preset text" scripts
Image Controls:	Manual/Auto control for brightness (shutter, iris or gain)
Image Recall:	Full-screen, live/recalled image
Comparison Measurement:	Area, multi-segment length and circle gauge comparison measurements supported
User Interface:	Simple drop-down menu-driven operation Menu navigation using joystick
Freeze Frame:	Freezes live image currently displayed on screen
Image Save:	Single-button activated quick-save feature
Memory:	64MB internal Flash memory
Image Storage:	Images can be stored in folders in internal 64MB flash memory or on removable memory
Removable Memory:	CompactFlash, Type 1, accepts all memory sizes
Video Output:	Composite, S-Video and USB® 2.0 full-VGA streaming digital video
Still Image Format:	BITMAP or JPEG (Super High, High or Low .JPG)
Video Record Format:	MPEG2 (High or Low), MPEG1 (High, Med or Low)
File Manager:	Embedded file manager software supporting: file and folder creation, naming, deleting. Store to internal flash (C:\); CompactFlash (A:\); copy between A:\ and C:\
International Language Support:	English, German, Italian or French languages for on-screen prompts. Additional languages available upon request.
Software Status:	On-screen software revision status display
Software Updates:	Field updateable via CompactFlash
Remote Control:	All functions may be remotely controlled by a PC operating the iView Remote PTZ application

Full System

- Portable carrying/shipping case contains the camera head, CCU, hand-held controller (PTZ140 and PTZ100). PTZ70 requires separate shipping case.
- Main cable requires separate carrying case

Case Dimensions:	65.3 cm (25.7 in) L x 56.1 cm (22.1 in) W x 27.2 cm (10.7 in) D
System Weight:	PTZ140: 23.3 kg (51.3 lb) PTZ100: 22.1 kg (48.5 lb) PTZ70: 22.8 kg (50.3 lb)

Specifications subject to change without notice.

Company Info:	Tel: 31114-370030	www.atexshop.com
Comm-Co	Fax: +31114-370029	www.ruggedshop.nl
Kreekzoom 9	E-mail: Info@comm-co.com	www.webpainter.nl
4561 GX Hulst	Website: http://www.comm-co.com	www.wavecomblog.com
The Netherlands	Webshop: http://www.ecommshop.com	www.eyectv.nl